

ALUMINUM CHANNEL DOLLIES - ACP-1824-9-HDL

APPROX WEIGHT: 22.98 lbs.
 DOES NOT INCLUDE WEIGHT OF POWER OR PACKAGING!!!

*** ANY ADDITIONS, DELETIONS, OR OMISSIONS MUST BE CORRECTED ON THIS DRAWING AS THIS DRAWING WILL BE CONSIDERED ALL INCLUSIVE ***

ALL GRAPHICS PROVIDED ARE FOR REFERENCE ONLY. IF CERTAIN DIMENSIONS ARE CRITICAL PLEASE VERIFY THOSE DIMENSIONS WITH YOUR SALESPERSON

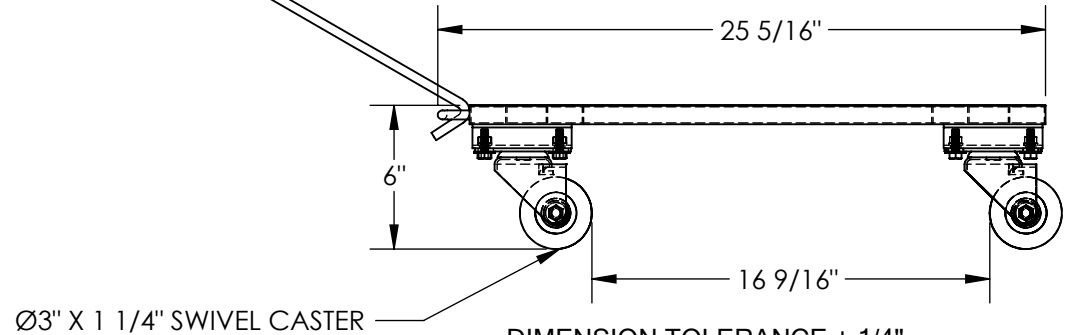
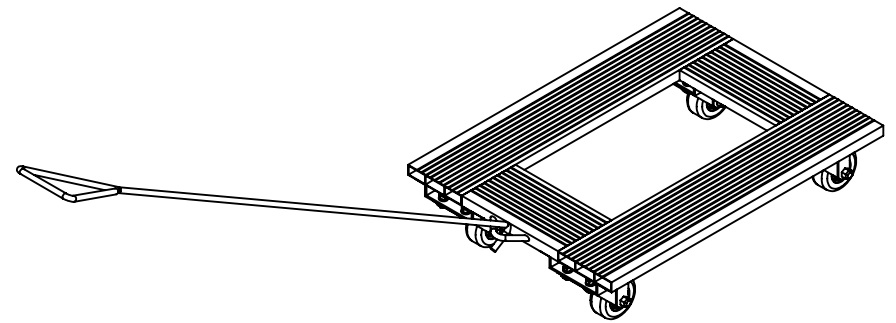
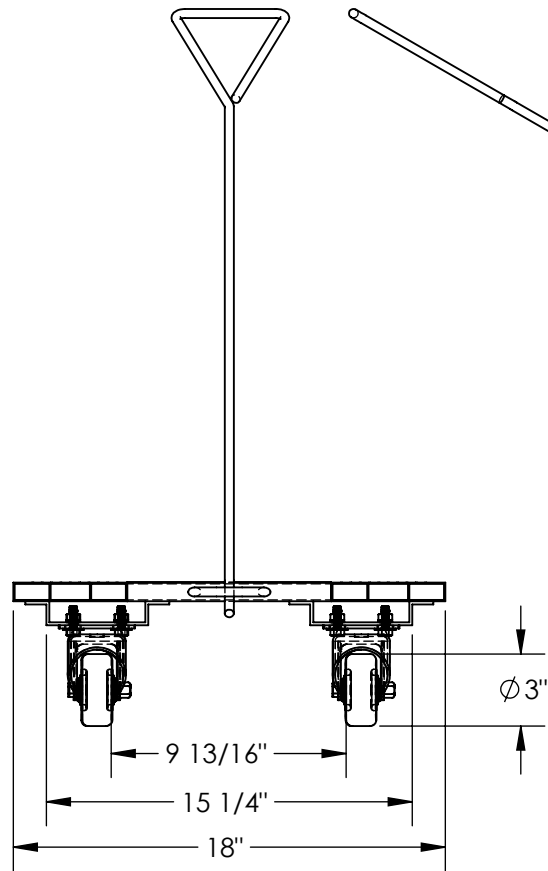

DIMENSION TOLERANCE $\pm 1/4$ "

STANDARD FEATURES

- MODEL NUMBER IS ACP-1824-9-HDL
- MAX CAPACITY IS 900 LBS
- OVERALL WIDTH IS 18"
- OVERALL LENGTH IS 25 5/16" WITHOUT HANDLE
- OVERALL HEIGHT IS 6"
- Ø3" X 1 1/4" HARD RUBBER CASTER
- 4- SWIVEL CASTERS
- 4 FOOT DETACHABLE HANDLE
- ALUMINUM CONSTRUCTION

SPECIAL FEATURES

NONE

APPROVAL

I, THE UNDERSIGNED, AGREE THAT THE PRODUCT AS REPRESENTED SATISFIES DESIGN AND DIMENSION REQUIREMENTS. I ALSO ACKNOWLEDGE MY DUTY TO CONFIRM PRODUCT AND INSTALLATION COMPLIANCE WITH ALL APPLICABLE FEDERAL, STATE AND LOCAL REGULATIONS AND STANDARDS.
UNITS REQUIRING APPROVAL DRAWINGS OR MODIFIED ARE NON-RETURNABLE

As drawn As marked

Signed: _____ Date: _____

Printed Name: _____

LEAD TIME WILL START UPON RECEIPT OF SIGNED APPROVAL DRAWING

DISTRIBUTOR'S NAME:		P.O.#
VESTIL MANUFACTURING		X
DRAWN BY: TCB		DATE: 12/14/2020
REFERENCE: X		SCALE: 1:8
QUOTED LEAD TIME: X	QUOTE #	FILE NAME:
	X	16-007-518